

Assembly Instruction

MERRYFAIR®

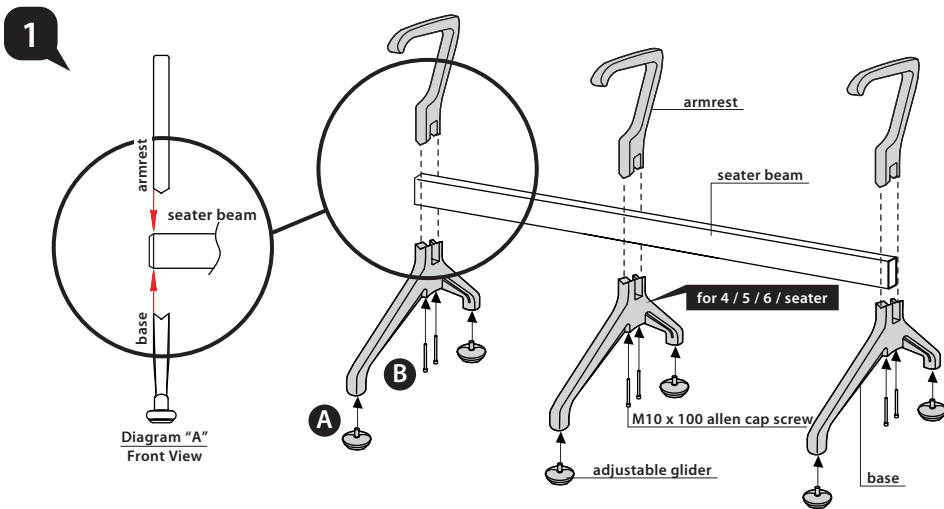

- A** Insert adjustable glider into base.
- B** Slot base and armrest into the seater beam and tighten with M10 X 100 allen cap screw.

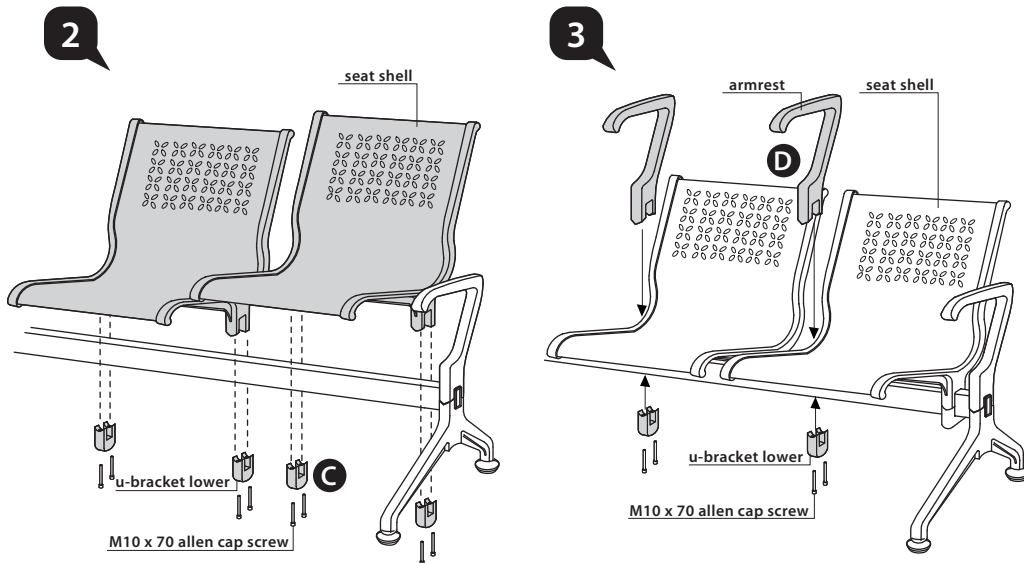

- C** Slot seat shell and u-bracket lower into seater beam (following measurement given) and tighten with M10 X 70 allen cap screw.
- D** Slot armrest and u-bracket lower into the seater beam (adjust the armrest so that it is at the center of 2 seat shell) and tighten with M10 X 70 allen cap screw.

Voyage

models: G140 / G150 / G160 / G170 / G220
B1 / B2 / B3 / B4 / B5 / B6 A28 J

remark: every seats C/W armrest

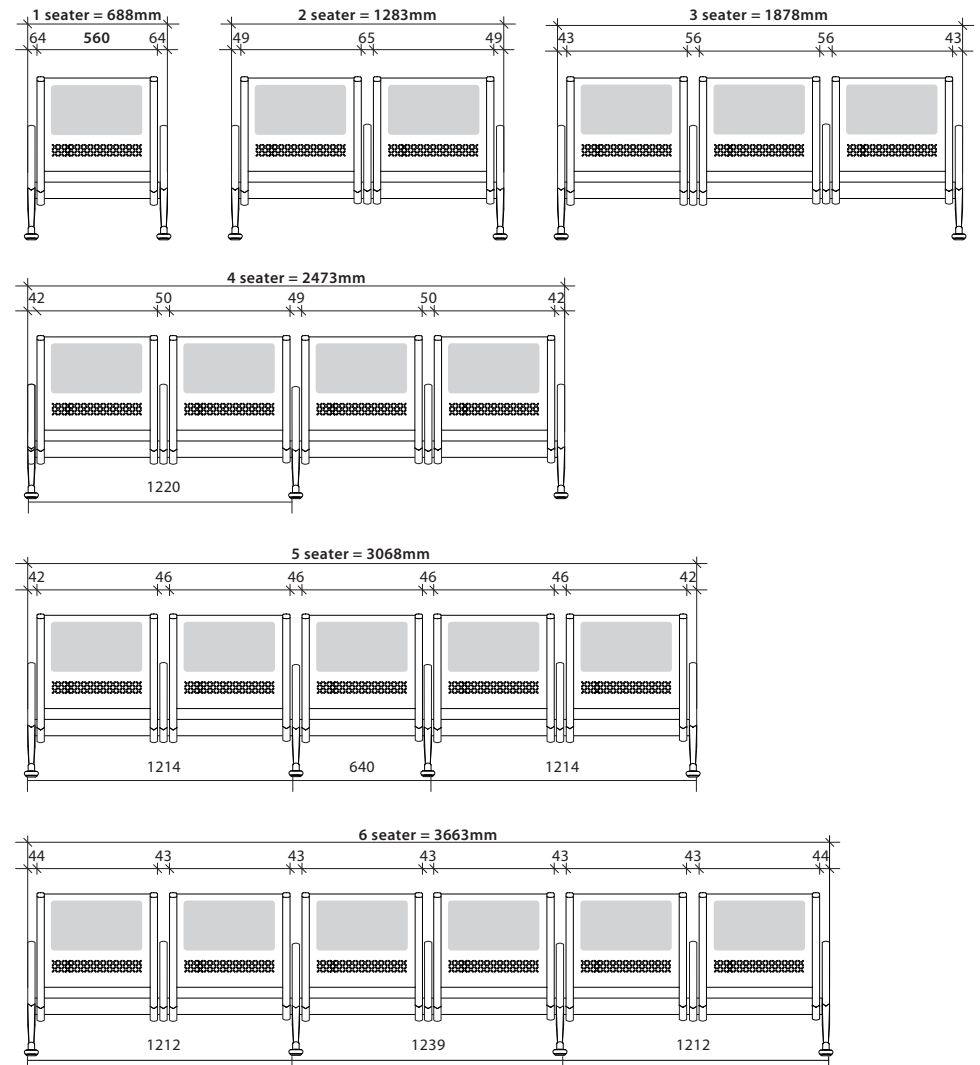

Assembly Instruction

MERRYFAIR®

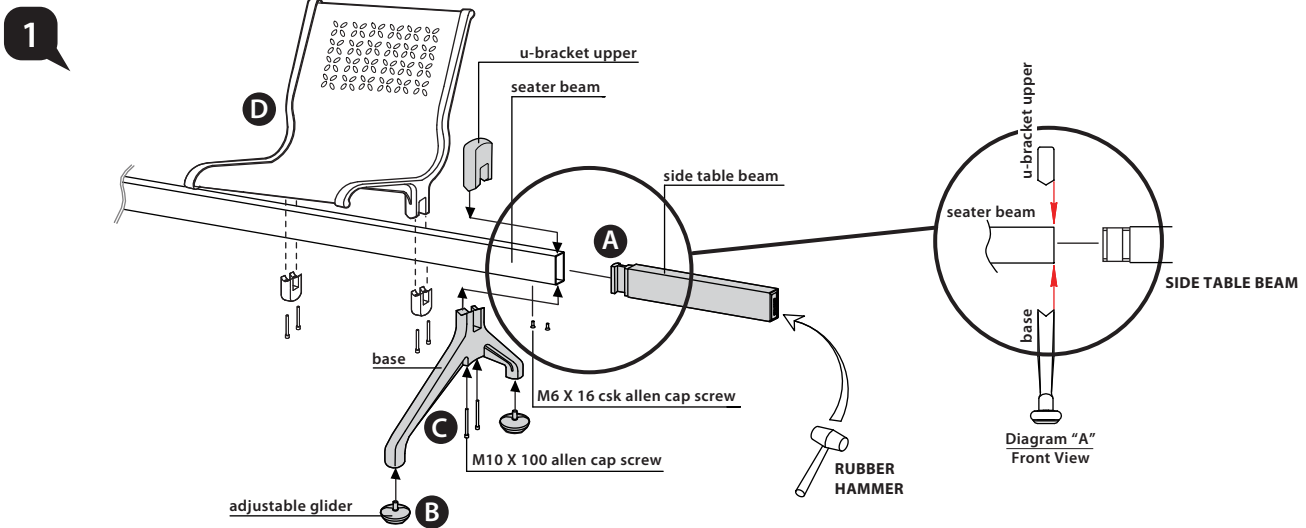

- A** Insert side table beam into one or both end side of seater beam by using rubber hammer and tighten with M6 X 16 CSK allen cap screw.
- B** Insert adjustable glider into base.
- C** Slot u-bracket upper (or armrest) & base into seater beam and tighten with M10 X 100 allen cap screw.
- D** Slot seat shell & u-bracket lower into seater beam and tighten with M10 X 70 allen cap screw.
(Please refer assembly instruction for **Voyage GXXX BX A00 J**)

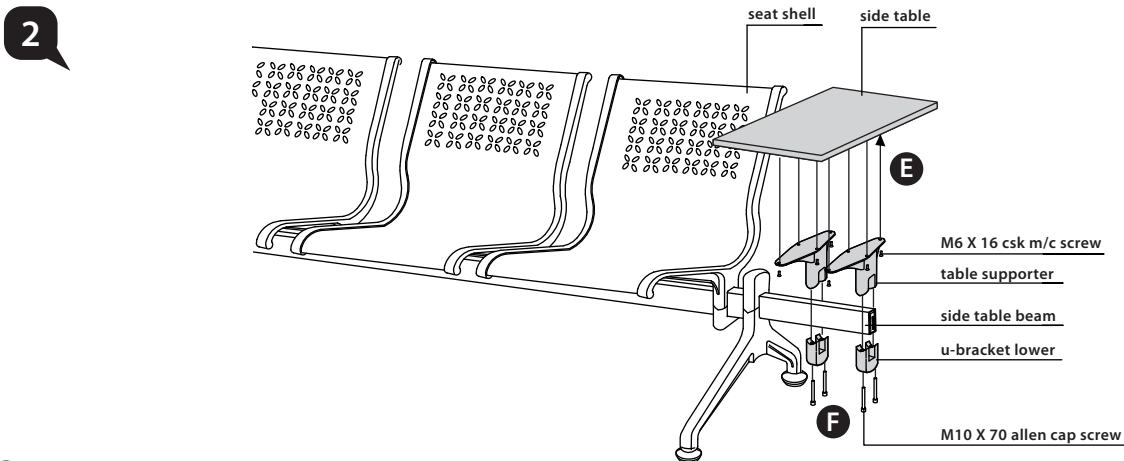

- E** Fix table supporter to side table with M6 X 16 CSK M/C screw.
- F** Slot side table + table supporter and u-bracket lower into side table beam and tighten with M10 X 70 allen cap screw.

Voyage

model: TS1 (Side Table)

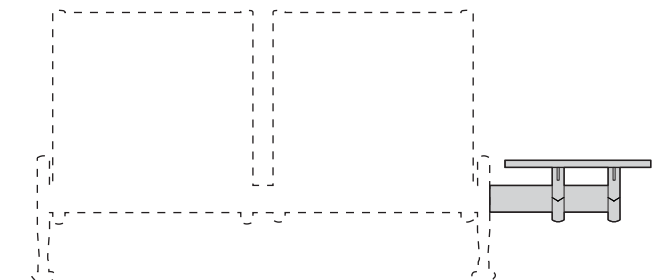
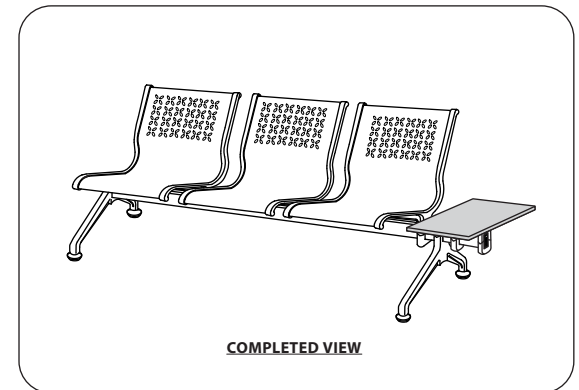

Assembly Instruction

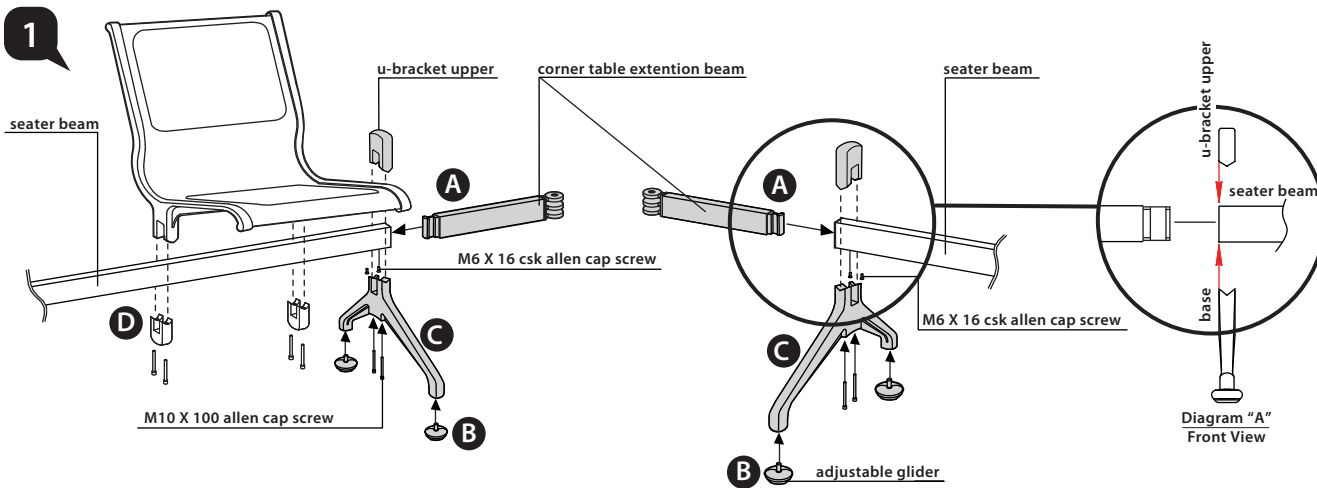

- A** Insert the corner table extension beam into end of seater beam by using rubber hammer and tighten with M6 X 16 CSK allen cap screw.
- B** Insert adjustable glider into base.
- C** Slot u-bracket upper (or armrest) & base into seater beam and tighten with M10 X 100 allen cap screw.
- D** Slot seat shell & u-bracket lower into seater beam and tighten with M10 X 70 allen cap screw.
(Please refer assembly instruction for **Voyage GXXX BX A00 J**)

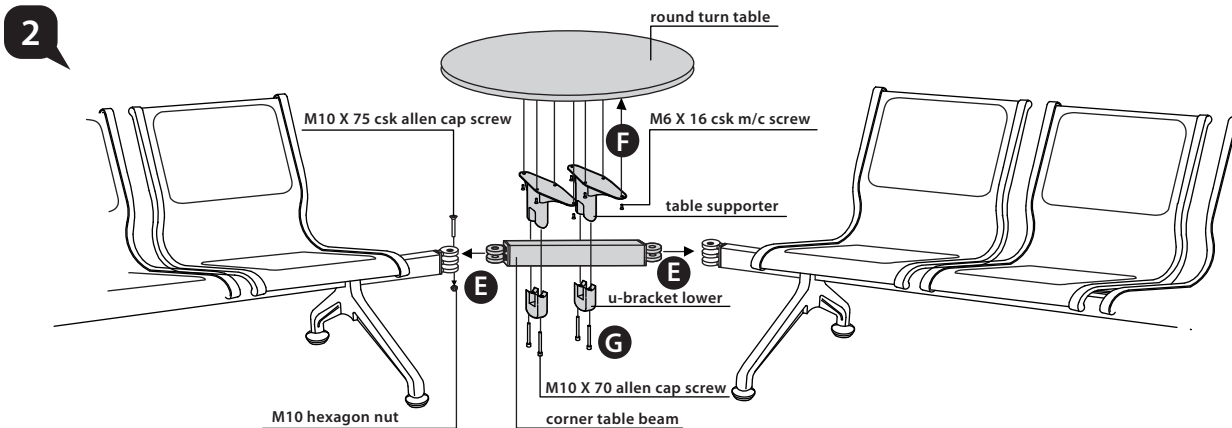

- E** Insert corner table beam into 2 different seater beam and tighten with M10 X 75 csk allen cap screw and M10 hexagon nut.
- F** Fix table supporter to round turn table with M6 X 16 csk m/c screw.
- G** Slot round turn table + table supporter and u-bracket lower into corner table beam and tighten with M10 X 70 allen cap screw.

Voyage

model: TT1 (Turn Table)

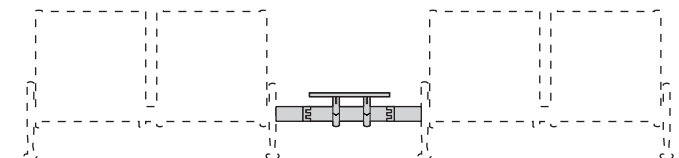
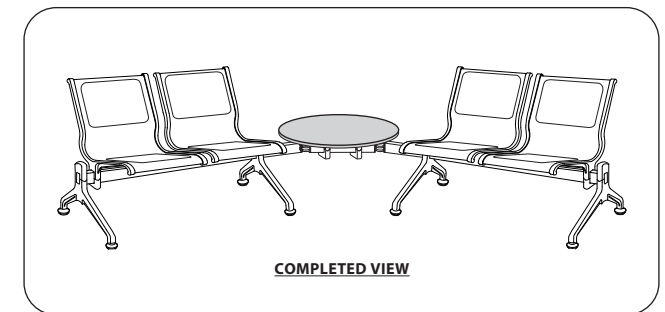

Assembly Instruction

MERRYFAIR®

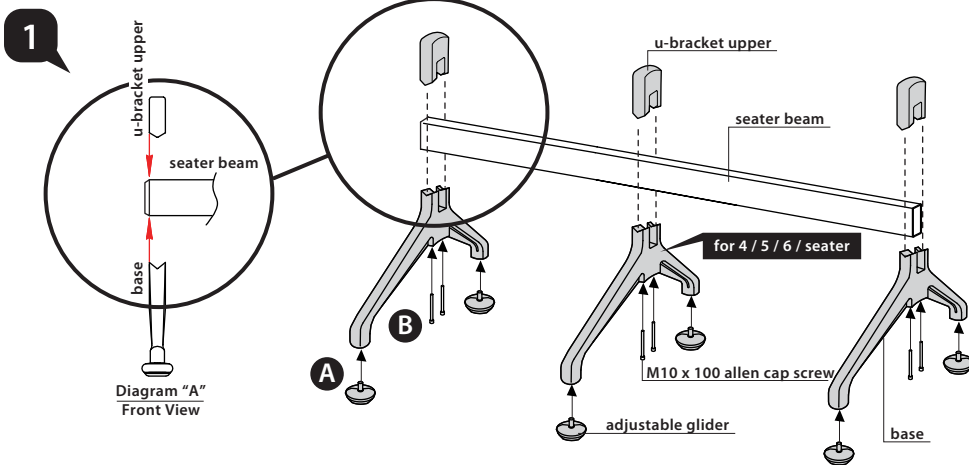

- A** Insert adjustable glider into base.
- B** Slot u-bracket upper & base into the seater beam and tighten with M10 X 100 allen cap screw.

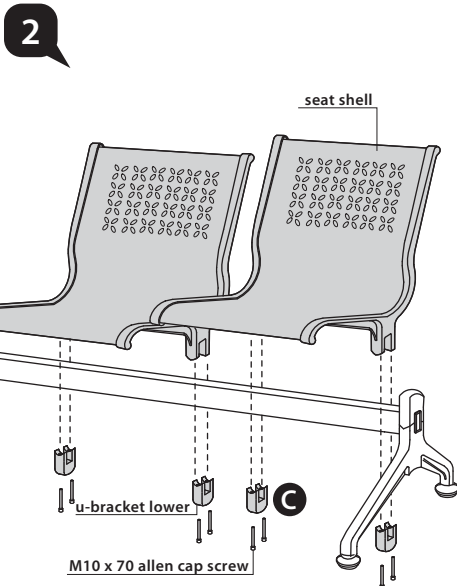

- C** Slot seat shell and u-bracket lower into seater beam (following measurement given) and tighten with M10 X 70 allen cap screw.

Change or add-in armrests after complete chair:

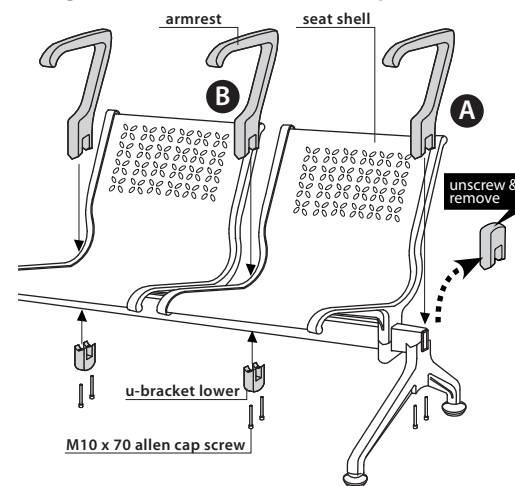

- A** Change u-bracket upper to armrest
unscrew & remove the u-bracket upper replace by armrest & tighten by using M10 X 100 allen cap screw.
- B** Add armrest in between seat
Slot armrest and u-bracket lower into the seater beam (adjust the armrest so that it is at the center of 2 seat shell) and tighten with M10 X 70 allen cap screw.

Voyage

models: G140 / G150 / G160 / G170 / G220
B1 / B2 / B3 / B4 / B5 / B6 A00 J

