

1

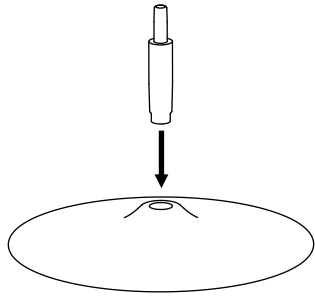

2

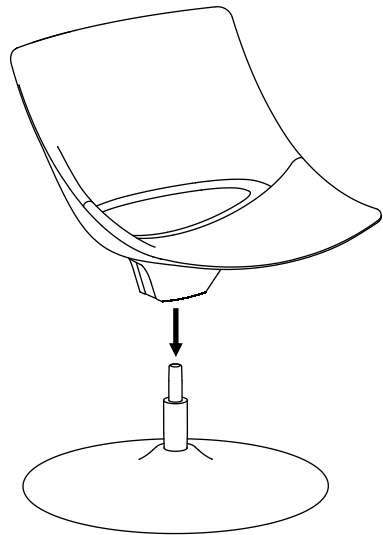

# TURINI

model 651 NA A00 AL  
652 NA A00 AL  
653 NA A00 AL

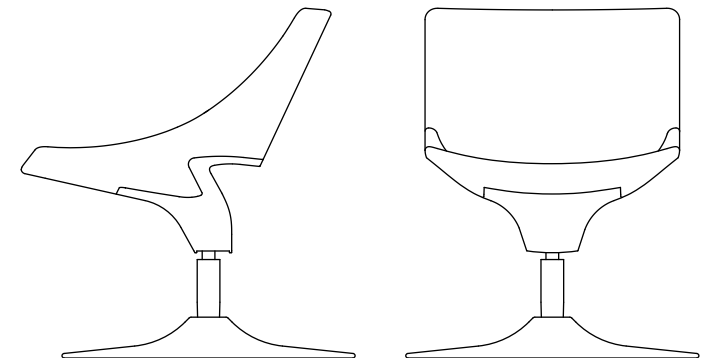

# Assembly Instruction

MERRYFAIR®

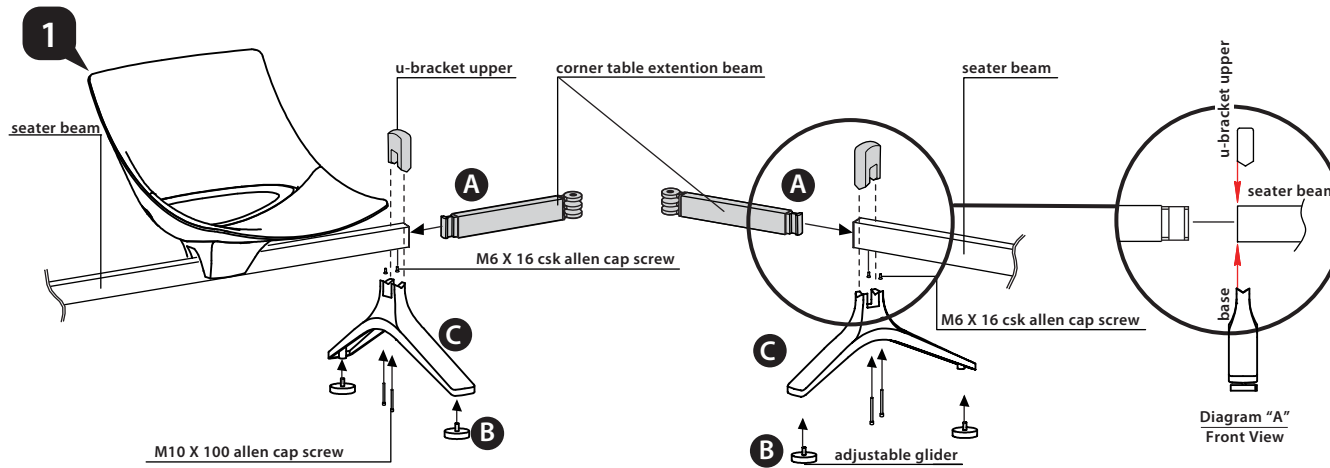

- A** Insert the corner table extension beam into end of seater beam by using rubber hammer and tighten with M6 X 16 CSK allen cap screw.
- B** Insert adjustable glider into base.
- C** Slot u-bracket upper (or armrest) & base into seater beam and tighten with M10 X 55 allen cap screw.

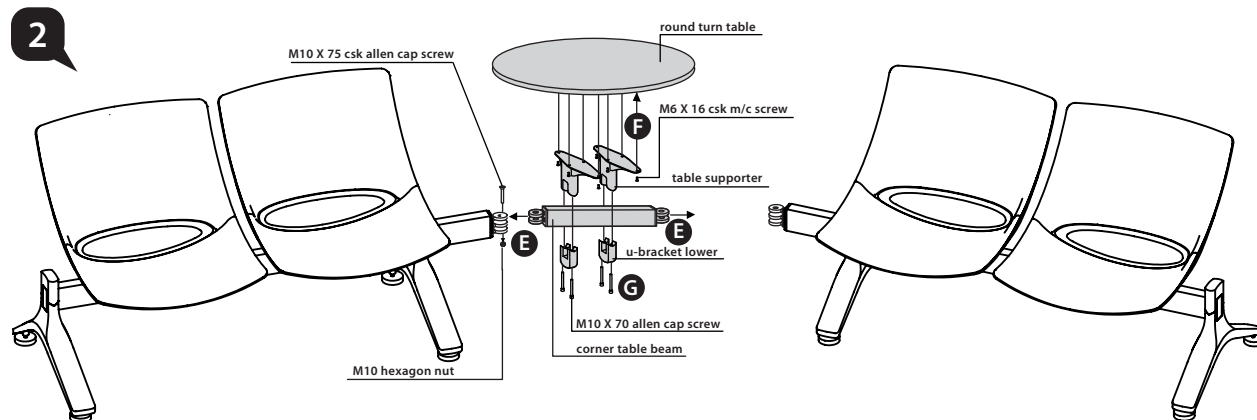

- E** Insert corner table beam into 2 different seater beam and tighten with M10 X 75 csk allen cap screw and M10 hexagon nut.
- F** Fix table supporter to round turn table with M6 X 16 csk m/c screw.
- G** Slot round turn table + table supporter and u-bracket lower into corner table beam and tighten with M10 X 70 allen cap screw.

## Turini

model: TT2 (Turn Table)

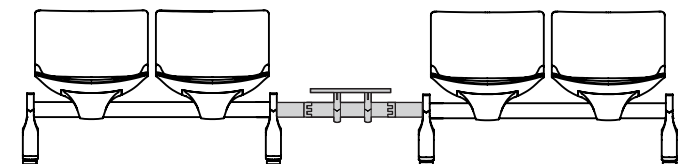
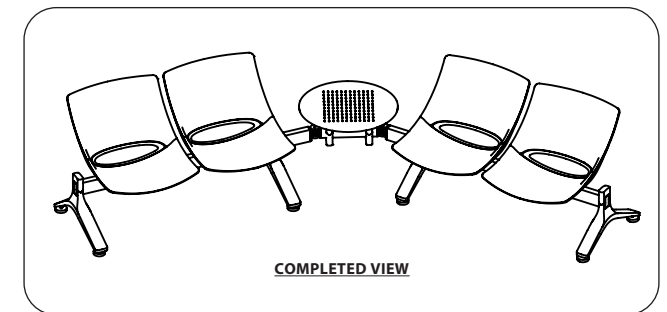

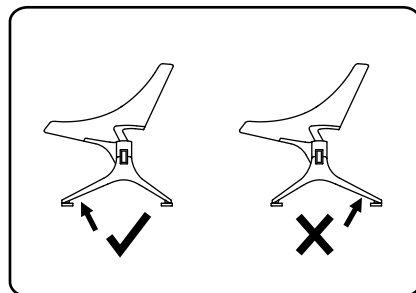
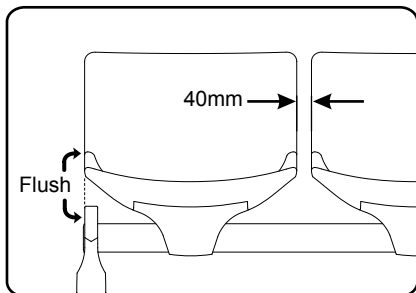
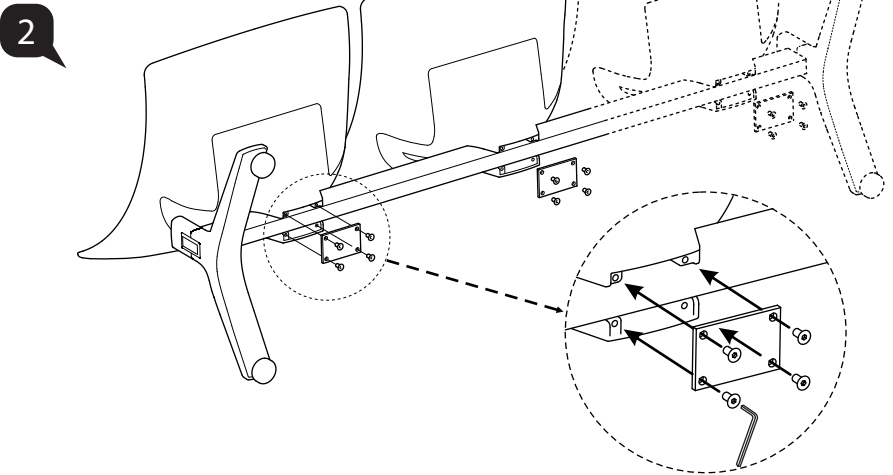
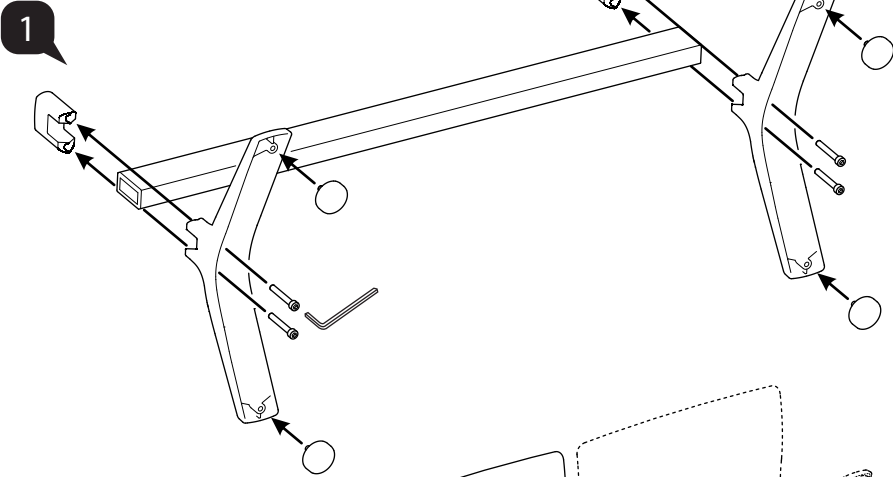

# TURINI

- model 65\_B2 A00 J
- 65\_B3 A00 J
- 65\_B4 A00 J
- 65\_B6 A00 J

