

# SPINELLY

models: 998P YK A77 NG  
998B YK A77 NP

## MERRYFAIR®

### ASSEMBLY INSTRUCTION

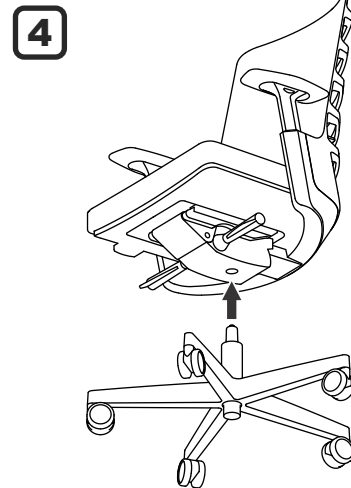
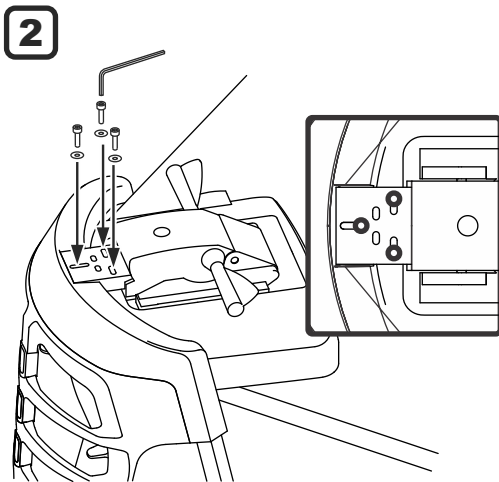
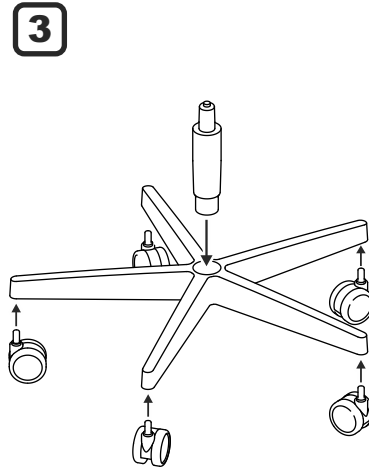
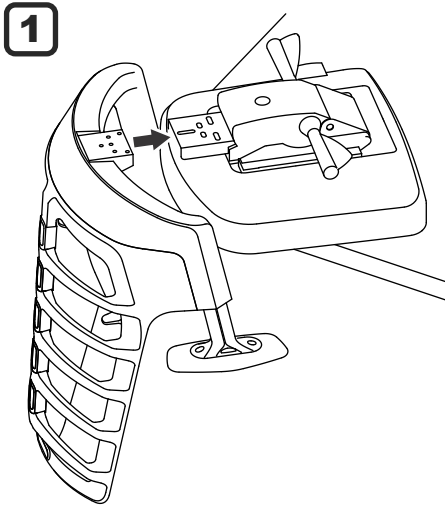

This chair is intended for indoor desk work use.

It is equipped with a swivel base and castors to be highly mobile. As such, NEVER stand on chair to reach for high items or sit on its table or armrests or back since it may move off unexpectedly and result in a falling HAZARD.

#### Care and Maintenance

With regular care and maintenance, your Merryfair SPINELLY seating will provide many years of superior performance and satisfaction. These instructions are provided to you as a service and no warranty is implied since results may vary.

#### Textile Surfaces

##### Normal Cleaning

For normal cleaning, vacuum fabric as needed using an upholstery attachment. Vacuuming picks up dust and reduces the need for professional cleaning. *Do not brush fabric or use a vacuum attachment with a rotary brush. Brushing may permanently damage the nap or change the character of the fabric.*

##### Spot Cleaning

To spot-clean fabric, immediately soak up the stain with a soft absorbent cloth. Do not dry the stain completely or it may set. The longer a stain is allowed to remain on a fabric, the more difficult it is to remove.

For water-based stains such as coffee, soft drinks, fruit juices, or milk use a water-based cleaner (specifically made for cleaning fabric) or a solution of mild (alkaline) warm soapy water (not overly soapy) applied with a damp clean cloth or sponge. Work the cleaner into a lather or foam. *Never use hot water; it will set the stain. Avoid scrubbing.*

For oil-based stains such as lipstick, grease, or salad dressing use a dry cleaning solution applied with a damp clean cloth or sponge. Test the cleaning solution on a small, concealed area first. If there is no spotting, ringing, or damage to the fabric or its dyes, apply the cleaning solution to the soiled area with light, quick strokes. Begin at the outside of the stain and work toward the center, being careful not to over-saturate the fabric.

Do not over apply water or any liquid solution to fabric. Excessive wetting of the fabric or any liquid solution may result in permanent damage to the material.

Do not rub too vigorously or you may damage the nap of the fabric or break fibers. Several light applications are better than one heavy application.

Soak up all remaining solution and then use another clean cloth or sponge dipped in cool water to remove any residue.

Let fabric dry thoroughly and then vacuum well before using. If the stain resists cleaning, call a professional cleaner.

#### Leather Surfaces

For normal cleaning, vacuum or dust frequently with a clean, dry cloth. If leather is soiled, it can be wiped with a soft cloth using specialized leather cleaner.

Do not spot clean leather; clean the entire surface. Wipe clean with a damp cloth and dry with a clean, soft cloth.

For spots and spills, wipe excess liquid immediately with a clean cloth or sponge; let the leather air dry. If further cleaning is necessary, sponge the entire surface with lukewarm water.

Let the leather air dry; never use a hair dryer or other heat source to dry leather. For stubborn spots and stains, apply a mild, nonabrasive soap solution with a clean, wet sponge. Rinse well and let air dry.

For butter, oil, or grease, wipe the leather with a clean, dry cloth and let the remainder of the oil dissipate into the leather. Do not apply water or try to wash a grease spot.

Do not use saddle soap, cleaning solvents, oils, furniture polishes, varnishes, abrasive cleaners, detergents, or ammonia on leather; they will ruin the finish, causing it to become sticky and cracked.

#### Plastic Surfaces – Seat, Back Shell, Base, Table

For normal cleaning, wash surface with a soft cloth soaked in mild detergent and warm water. Rinse thoroughly and dry with a soft cloth. Do not use solvents or abrasive kitchen cleaners.

#### Epoxy powder-coated Metal – Table Support Arm

For normal cleaning, wash coated metal surfaces with a soft cloth soaked in detergent and warm water; rinse thoroughly and dry.

Remove scuff marks from low-gloss coatings with pre-softened paste wax, following the manufacturer's instructions. Remove scuff marks and scratches from high-gloss coatings using automotive polishing compounds, either liquid or paste. After polishing, apply a pre-softened automotive paste wax to restore original sheen.

#### Moving Parts

The moving parts of the chair do not require servicing or lubrication by the user. The adjustment and tilt mechanisms and swivel column are NOT user serviceable components.

**IMPORTANT NOTE:** The swivel column contains a high-pressure gas spring which can cause harm if mishandled by untrained personnel. Please call for authorised service personnel if any of these components malfunction.

# SPINELLY

models: 998P YM A77 NG  
998B YM A77 NP

## ASSEMBLY INSTRUCTION

# MERRYFAIR

This chair is intended for indoor desk work use. It is equipped with a swivel base and castors to be highly mobile. As such, NEVER stand on chair to reach for high items or sit on its table or armrests or back since it may move off unexpectedly and result in a falling HAZARD.

## USER INSTRUCTIONS

- A Seat Height Adjustment**  
Flip up lever on right-side to raise or lower seat. Adjust such that your feet are adequately supported on floor.
- B Multi-Position Tilt Lock**  
Recline to desired position, and flip down lever on left-side to lock. Flip up lever and recline to release tilt-lock.
- C Armrest Height**  
Pull button to unlock armrest and raise or lower it to desired height, and release button to lock. Adjust such that elbows are resting on armpads without straining the shoulders.
- D Lumbar Pad Height**  
Pinch both levers and slide lumbar pad up or down to preferred position.

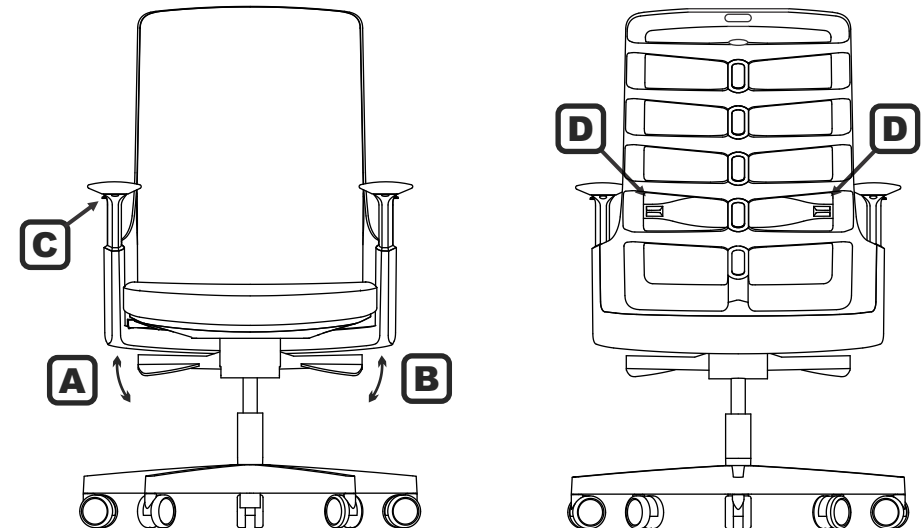
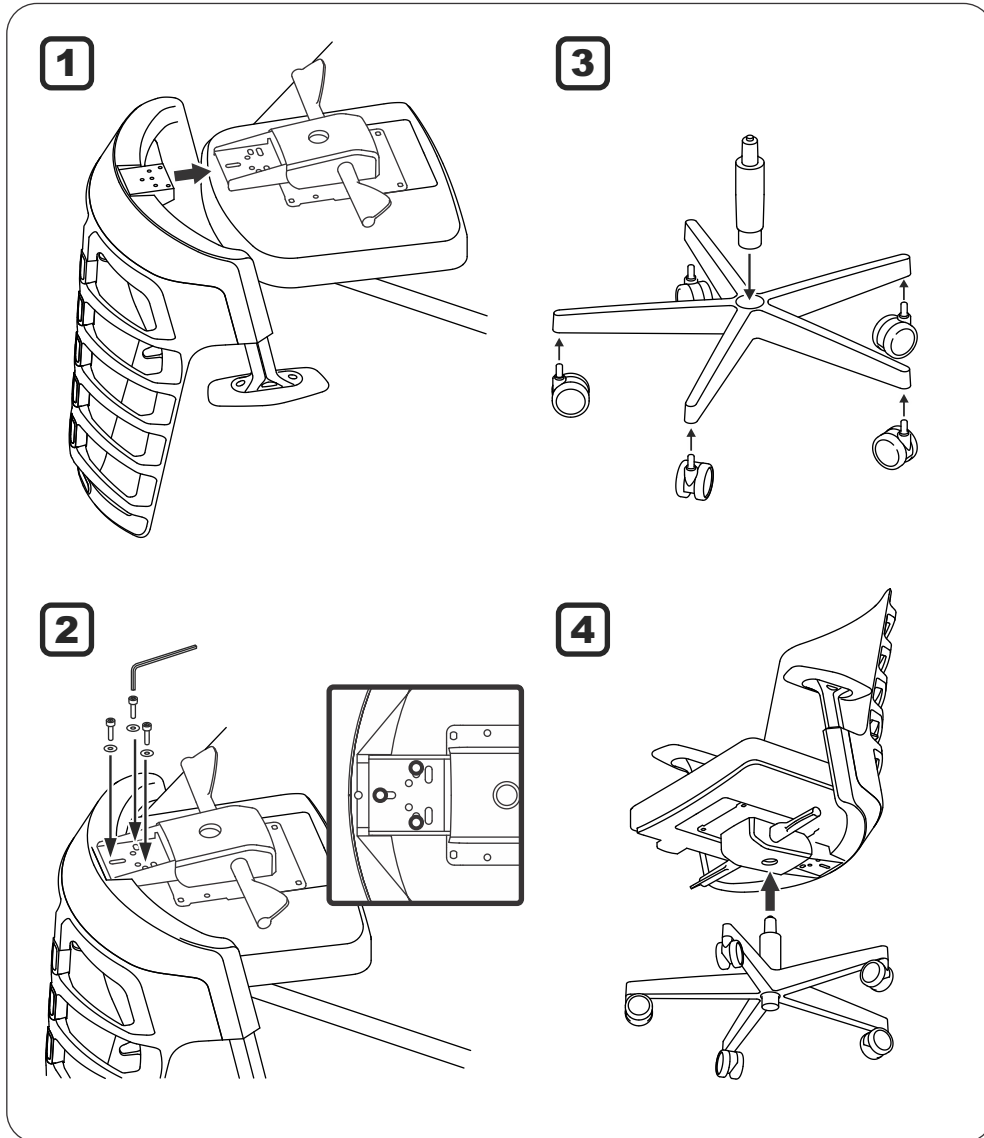

# SPINELLY

models: 998P YM A77 NG  
998B YM A77 NP

## ASSEMBLY INSTRUCTION

# MERRYFAIR

This chair is intended for indoor desk work use.

It is equipped with a swivel base and castors to be highly mobile. As such, NEVER stand on chair to reach for high items or sit on its table or armrests or back since it may move off unexpectedly and result in a falling HAZARD.

### Care and Maintenance

With regular care and maintenance, your Merryfair SPINELLY seating will provide many years of superior performance and satisfaction. These instructions are provided to you as a service and no warranty is implied since results may vary.

#### Textile Surfaces

##### Normal Cleaning

For normal cleaning, vacuum fabric as needed using an upholstery attachment. Vacuuming picks up dust and reduces the need for professional cleaning. *Do not brush fabric or use a vacuum attachment with a rotary brush. Brushing may permanently damage the nap or change the character of the fabric.*

##### Spot Cleaning

To spot-clean fabric, immediately soak up the stain with a soft absorbent cloth. Do not dry the stain completely or it may set. The longer a stain is allowed to remain on a fabric, the more difficult it is to remove.

For water-based stains such as coffee, soft drinks, fruit juices, or milk use a water-based cleaner (specifically made for cleaning fabric) or a solution of mild (alkaline) warm soapy water (not overly soapy) applied with a damp clean cloth or sponge. Work the cleaner into a lather or foam. *Never use hot water; it will set the stain. Avoid scrubbing.*

For oil-based stains such as lipstick, grease, or salad dressing use a dry cleaning solution applied with a damp clean cloth or sponge. Test the cleaning solution on a small, concealed area first. If there is no spotting, ringing, or damage to the fabric or its dyes, apply the cleaning solution to the soiled area with light, quick strokes. Begin at the outside of the stain and work toward the center, being careful not to over-saturate the fabric.

Do not over apply water or any liquid solution to fabric. Excessive wetting of the fabric with any liquid solution may result in permanent damage to the material.

Do not rub too vigorously or you may damage the nap of the fabric or break fibers. Several light applications are better than one heavy application.

Soak up all remaining solution and then use another clean cloth or sponge dipped in cool water to remove any residue.

Let fabric dry thoroughly and then vacuum well before using. If the stain resists cleaning, call a professional cleaner.

#### Leather Surfaces

For normal cleaning, vacuum or dust frequently with a clean, dry cloth. If leather is soiled, it can be wiped with a soft cloth using specialized leather cleaner.

Do not spot clean leather; clean the entire surface. Wipe clean with a damp cloth and dry with a clean, soft cloth.

For spots and spills, wipe excess liquid immediately with a clean cloth or sponge; let the leather air dry. If further cleaning is necessary, sponge the entire surface with lukewarm water.

Let the leather air dry; never use a hair dryer or other heat source to dry leather. For stubborn spots and stains, apply a mild, nonabrasive soap solution with a clean, wet sponge. Rinse well and let air dry.

For butter, oil, or grease, wipe the leather with a clean, dry cloth and let the remainder of the oil dissipate into the leather. Do not apply water or try to wash a grease spot.

Do not use saddle soap, cleaning solvents, oils, furniture polishes, varnishes, abrasive cleaners, detergents, or ammonia on leather; they will ruin the finish, causing it to become sticky and cracked.

#### Plastic Surfaces – Seat, Back Shell, Base, Table

For normal cleaning, wash surface with a soft cloth soaked in mild detergent and warm water. Rinse thoroughly and dry with a soft cloth. Do not use solvents or abrasive kitchen cleaners.

#### Epoxy powder-coated Metal – Table Support Arm

For normal cleaning, wash coated metal surfaces with a soft cloth soaked in detergent and warm water; rinse thoroughly and dry.

Remove scuff marks from low-gloss coatings with pre-softened paste wax, following the manufacturer's instructions. Remove scuff marks and scratches from high-gloss coatings using automotive polishing compounds, either liquid or paste. After polishing, apply a pre-softened automotive paste wax to restore original sheen.

#### Moving Parts

The moving parts of the chair do not require servicing or lubrication by the user. The adjustment and tilt mechanisms and swivel column are NOT user serviceable components.

**IMPORTANT NOTE:** The swivel column contains a high-pressure gas spring which can cause harm if mishandled by untrained personnel. Please call for authorised service personnel if any of these components malfunction.

1

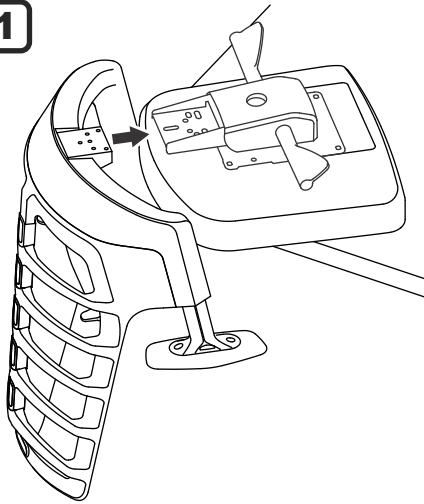

3

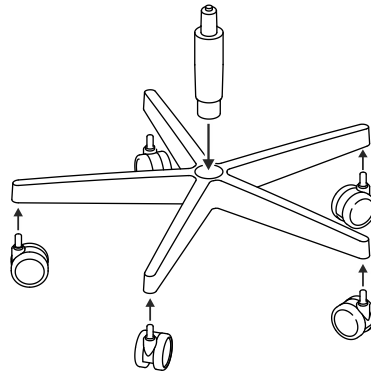

2

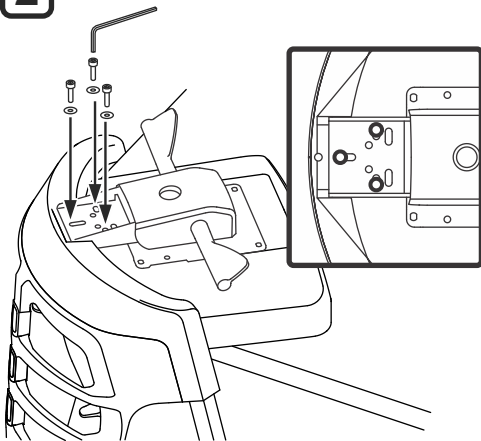

4

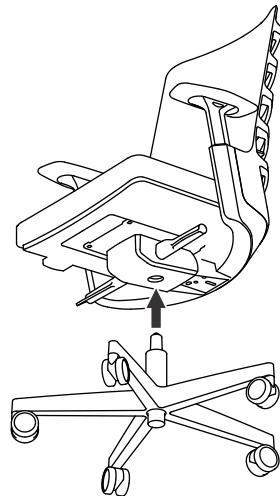

# SPINELLY

models: 999P YK A77 NG  
999B YK A77 NP

## ASSEMBLY INSTRUCTION

# MERRYFAIR®

This chair is intended for indoor desk work use.

It is equipped with a swivel base and castors to be highly mobile. As such, NEVER stand on chair to reach for high items or sit on its table or armrests or back since it may move off unexpectedly and result in a falling HAZARD.

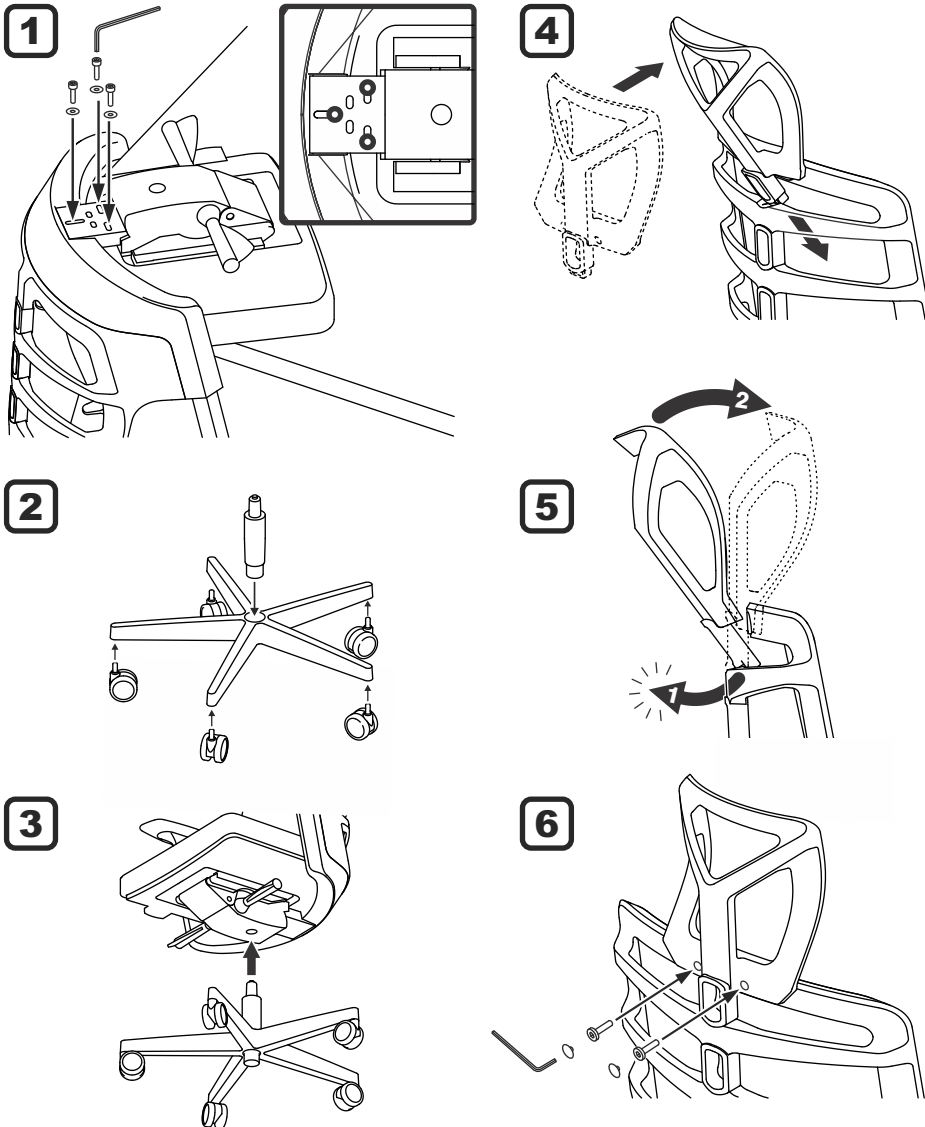

### Care and Maintenance

With regular care and maintenance, your Merryfair SPINELLY seating will provide many years of superior performance and satisfaction. These instructions are provided to you as a service and no warranty is implied since results may vary.

#### Textile Surfaces

##### Normal Cleaning

For normal cleaning, vacuum fabric as needed using an upholstery attachment. Vacuuming picks up dust and reduces the need for professional cleaning. *Do not brush fabric or use a vacuum attachment with a rotary brush. Brushing may permanently damage the nap or change the character of the fabric.*

##### Spot Cleaning

To spot-clean fabric, immediately soak up the stain with a soft absorbent cloth. Do not dry the stain completely or it may set. The longer a stain is allowed to remain on a fabric, the more difficult it is to remove.

For water-based stains such as coffee, soft drinks, fruit juices, or milk use a water-based cleaner (specifically made for cleaning fabric) or a solution of mild (alkaline) warm soapy water (not overly soapy) applied with a damp clean cloth or sponge. Work the cleaner into a lather or foam. *Never use hot water; it will set the stain. Avoid scrubbing.*

For oil-based stains such as lipstick, grease, or salad dressing use a dry cleaning solution applied with a damp clean cloth or sponge. Test the cleaning solution on a small, concealed area first. If there is no spotting, ringing, or damage to the fabric or its dyes, apply the cleaning solution to the soiled area with light, quick strokes. Begin at the outside of the stain and work toward the center, being careful not to over-saturate the fabric.

Do not over apply water or any liquid solution to fabric. Excessive wetting of the fabric with any liquid solution may result in permanent damage to the material.

Do not rub too vigorously or you may damage the nap of the fabric or break fibers. Several light applications are better than one heavy application.

Soak up all remaining solution and then use another clean cloth or sponge dipped in cool water to remove any residue.

Let fabric dry thoroughly and then vacuum well before using. If the stain resists cleaning, call a professional cleaner.

#### Leather Surfaces

For normal cleaning, vacuum or dust frequently with a clean, dry cloth. If leather is soiled, it can be wiped with a soft cloth using specialized leather cleaner.

Do not spot clean leather; clean the entire surface. Wipe clean with a damp cloth and dry with a clean, soft cloth.

For spots and spills, wipe excess liquid immediately with a clean cloth or sponge; let the leather air dry. If further cleaning is necessary, sponge the entire surface with lukewarm water.

Let the leather air dry; never use a hair dryer or other heat source to dry leather. For stubborn spots and stains, apply a mild, nonabrasive soap solution with a clean, wet sponge. Rinse well and let air dry.

For butter, oil, or grease, wipe the leather with a clean, dry cloth and let the remainder of the oil dissipate into the leather. Do not apply water or try to wash a grease spot.

Do not use saddle soap, cleaning solvents, oils, furniture polishes, varnishes, abrasive cleaners, detergents, or ammonia on leather; they will ruin the finish, causing it to become sticky and cracked.

#### Plastic Surfaces – Seat, Back Shell, Base, Table

For normal cleaning, wash surface with a soft cloth soaked in mild detergent and warm water. Rinse thoroughly and dry with a soft cloth. Do not use solvents or abrasive kitchen cleaners.

#### Epoxy powder-coated Metal – Table Support Arm

For normal cleaning, wash coated metal surfaces with a soft cloth soaked in detergent and warm water; rinse thoroughly and dry.

Remove scuff marks from low-gloss coatings with pre-softened paste wax, following the manufacturer's instructions. Remove scuff marks and scratches from high-gloss coatings using automotive polishing compounds, either liquid or paste. After polishing, apply a pre-softened automotive paste wax to restore original sheen.

#### Moving Parts

The moving parts of the chair do not require servicing or lubrication by the user. The adjustment and tilt mechanisms and swivel column are NOT user serviceable components.

**IMPORTANT NOTE:** The swivel column contains a high-pressure gas spring which can cause harm if mishandled by untrained personnel. Please call for authorised service personnel if any of these components malfunction.

# SPINELLY

models: 999P YK A77 NG  
999B YK A77 NP

## ASSEMBLY INSTRUCTION

# MERRYFAIR®

This chair is intended for indoor desk work use. It is equipped with a swivel base and castors to be highly mobile. As such, NEVER stand on chair to reach for high items or sit on its table or armrests or back since it may move off unexpectedly and result in a falling HAZARD.

## USER INSTRUCTIONS

- A Seat Height Adjustment**  
Flip up lever on right-side to raise or lower seat. Adjust such that your feet are adequately supported on floor.
- B Multi-Position Tilt Lock**  
Recline to desired position, and flip down lever on left-side to lock. Flip up lever and recline to release tilt-lock.
- C Tilt Tension fine adjust**  
This chair is equipped with an auto-weight sensing Tilt Tension mechanism. Recline force is automatically adjusted between different users. However, this can be further fine-tuned to suit individual preference by a bottom knob. Turn clockwise to slightly increase tilt tension, and vice-versa.
- D Armrest Height**  
Pull button to unlock armrest and raise or lower it to desired height, and release button to lock. Adjust such that elbows are resting on armpads without straining the shoulders.
- E Lumbar Pad Height**  
Pinch both levers and slide lumbar pad up or down to preferred position.

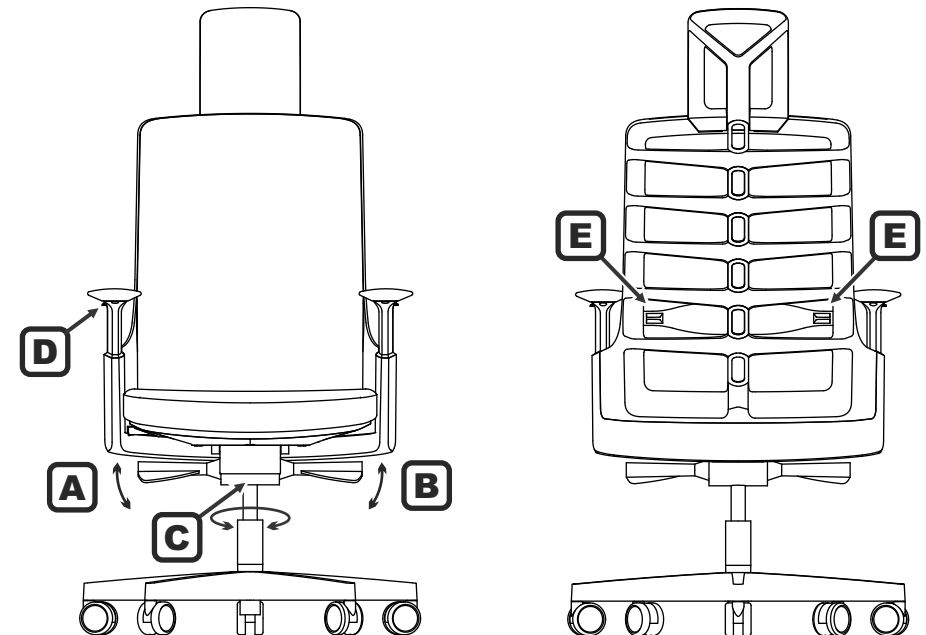
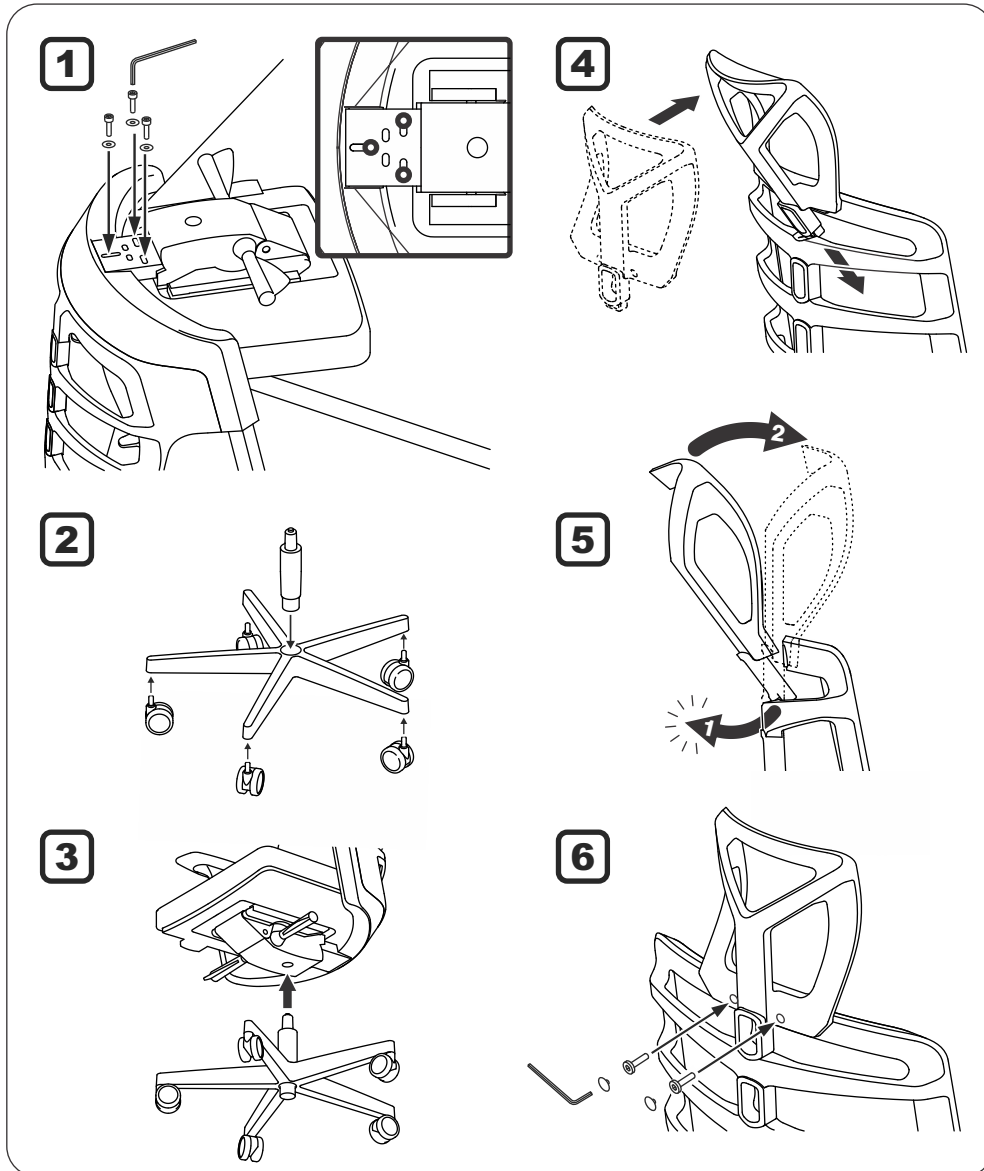



# SPINELLY

models: 999P YM A77 NG  
999B YM A77 NP

## ASSEMBLY INSTRUCTION

# MERRYFAIR

This chair is intended for indoor desk work use.

It is equipped with a swivel base and castors to be highly mobile. As such, NEVER stand on chair to reach for high items or sit on its table or armrests or back since it may move off unexpectedly and result in a falling HAZARD.

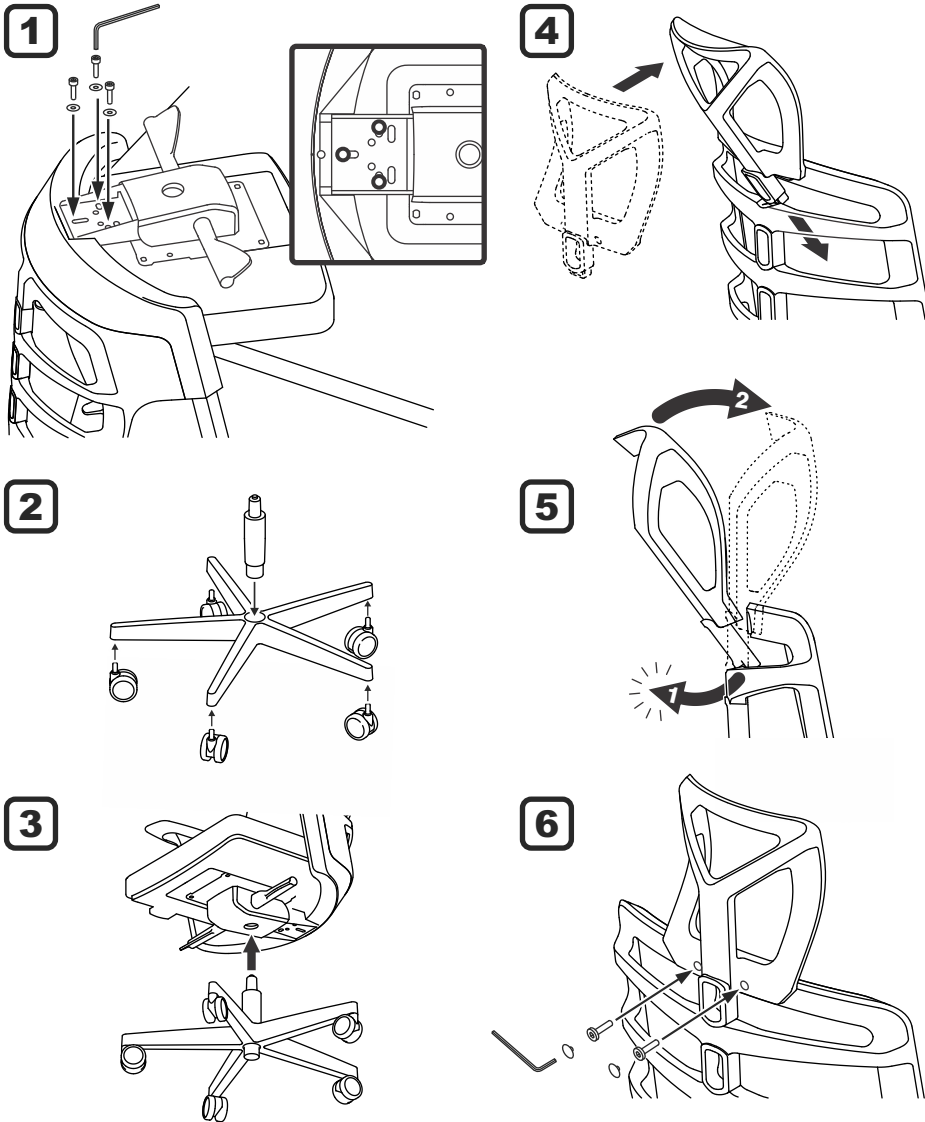

### Care and Maintenance

With regular care and maintenance, your Merryfair SPINELLY seating will provide many years of superior performance and satisfaction. These instructions are provided to you as a service and no warranty is implied since results may vary.

#### Textile Surfaces

##### Normal Cleaning

For normal cleaning, vacuum fabric as needed using an upholstery attachment. Vacuuming picks up dust and reduces the need for professional cleaning. *Do not brush fabric or use a vacuum attachment with a rotary brush. Brushing may permanently damage the nap or change the character of the fabric.*

##### Spot Cleaning

To spot-clean fabric, immediately soak up the stain with a soft absorbent cloth. Do not dry the stain completely or it may set. The longer a stain is allowed to remain on a fabric, the more difficult it is to remove.

For water-based stains such as coffee, soft drinks, fruit juices, or milk use a water-based cleaner (specifically made for cleaning fabric) or a solution of mild (alkaline) warm soapy water (not overly soapy) applied with a damp clean cloth or sponge. Work the cleaner into a lather or foam. *Never use hot water; it will set the stain. Avoid scrubbing.*

For oil-based stains such as lipstick, grease, or salad dressing use a dry cleaning solution applied with a damp clean cloth or sponge. Test the cleaning solution on a small, concealed area first. If there is no spotting, ringing, or damage to the fabric or its dyes, apply the cleaning solution to the soiled area with light, quick strokes. Begin at the outside of the stain and work toward the center, being careful not to over-saturate the fabric.

Do not over apply water or any liquid solution to fabric. Excessive wetting of the fabric with any liquid solution may result in permanent damage to the material.

Do not rub too vigorously or you may damage the nap of the fabric or break fibers. Several light applications are better than one heavy application.

Soak up all remaining solution and then use another clean cloth or sponge dipped in cool water to remove any residue.

Let fabric dry thoroughly and then vacuum well before using. If the stain resists cleaning, call a professional cleaner.

#### Leather Surfaces

For normal cleaning, vacuum or dust frequently with a clean, dry cloth. If leather is soiled, it can be wiped with a soft cloth using specialized leather cleaner.

Do not spot clean leather; clean the entire surface. Wipe clean with a damp cloth and dry with a clean, soft cloth.

For spots and spills, wipe excess liquid immediately with a clean cloth or sponge; let the leather air dry. If further cleaning is necessary, sponge the entire surface with lukewarm water.

Let the leather air dry; never use a hair dryer or other heat source to dry leather. For stubborn spots and stains, apply a mild, nonabrasive soap solution with a clean, wet sponge. Rinse well and let air dry.

For butter, oil, or grease, wipe the leather with a clean, dry cloth and let the remainder of the oil dissipate into the leather. Do not apply water or try to wash a grease spot.

Do not use saddle soap, cleaning solvents, oils, furniture polishes, varnishes, abrasive cleaners, detergents, or ammonia on leather; they will ruin the finish, causing it to become sticky and cracked.

#### Plastic Surfaces – Seat, Back Shell, Base, Table

For normal cleaning, wash surface with a soft cloth soaked in mild detergent and warm water. Rinse thoroughly and dry with a soft cloth. Do not use solvents or abrasive kitchen cleaners.

#### Epoxy powder-coated Metal – Table Support Arm

For normal cleaning, wash coated metal surfaces with a soft cloth soaked in detergent and warm water; rinse thoroughly and dry.

Remove scuff marks from low-gloss coatings with pre-softened paste wax, following the manufacturer's instructions. Remove scuff marks and scratches from high-gloss coatings using automotive polishing compounds, either liquid or paste. After polishing, apply a pre-softened automotive paste wax to restore original sheen.

#### Moving Parts

The moving parts of the chair do not require servicing or lubrication by the user. The adjustment and tilt mechanisms and swivel column are NOT user serviceable components.

**IMPORTANT NOTE:** The swivel column contains a high-pressure gas spring which can cause harm if mishandled by untrained personnel. Please call for authorised service personnel if any of these components malfunction.

# SPINELLY

models: 999P YM A77 NG  
999B YM A77 NP

## ASSEMBLY INSTRUCTION

# MERRYFAIR

This chair is intended for indoor desk work use.  
It is equipped with a swivel base and castors to be highly mobile. As such, NEVER stand on chair to reach for high items or sit on its table or armrests or back since it may move off unexpectedly and result in a falling HAZARD.

## USER INSTRUCTIONS

- A Seat Height Adjustment**  
Flip up lever on right-side to raise or lower seat. Adjust such that your feet are adequately supported on floor.
- B Multi-Position Tilt Lock**  
Recline to desired position, and flip down lever on left-side to lock. Flip up lever and recline to release tilt-lock.
- C Armrest Height**  
Pull button to unlock armrest and raise or lower it to desired height, and release button to lock. Adjust such that elbows are resting on armpads without straining the shoulders.
- D Lumbar Pad Height**  
Pinch both levers and slide lumbar pad up or down to preferred position.

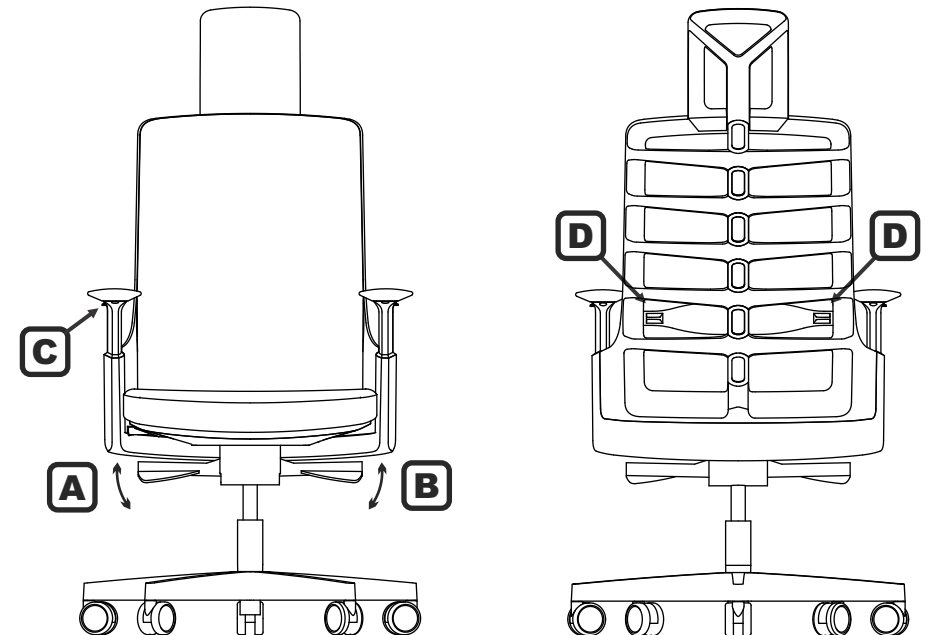
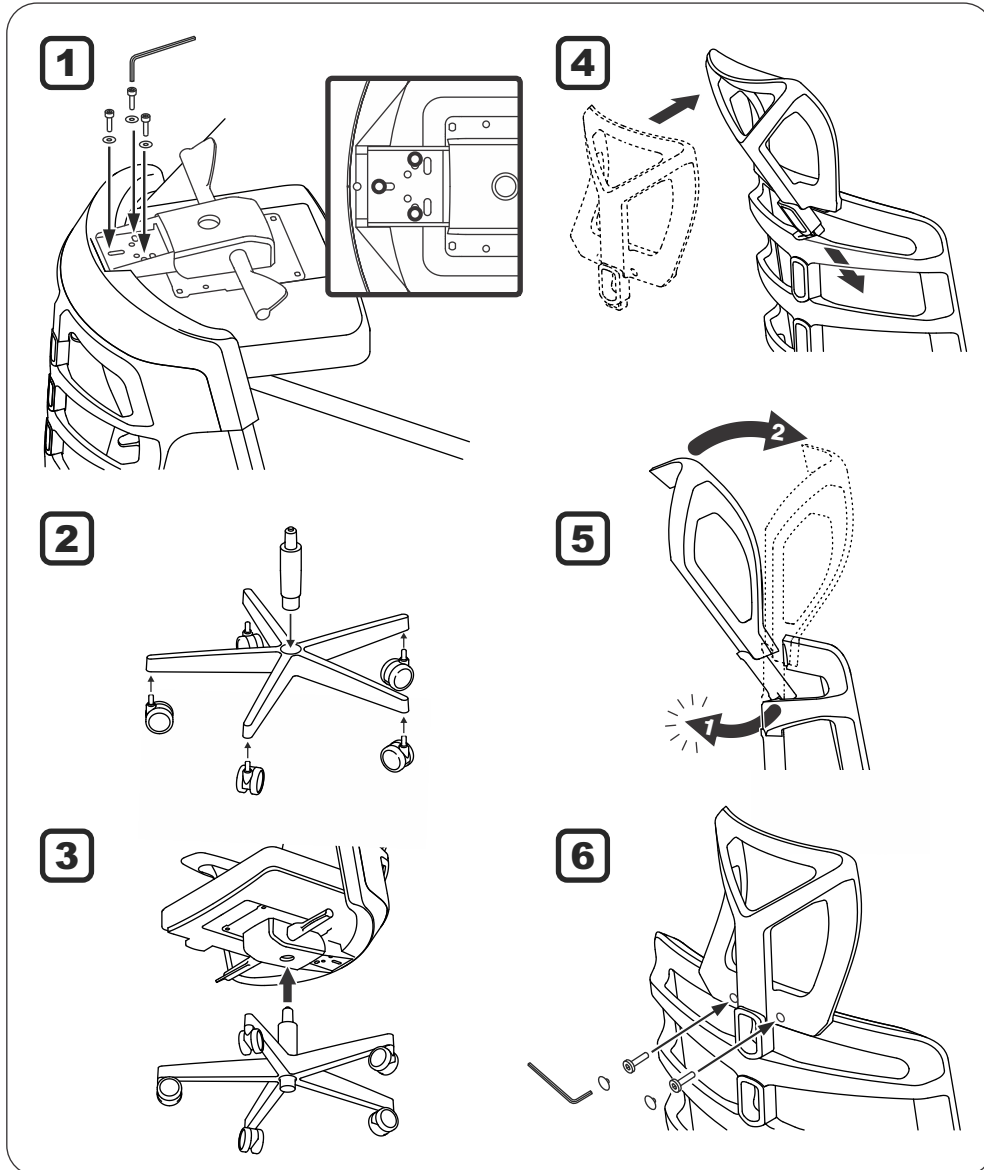

# SPINELLY

models: MSC999HRS1

## MERRYFAIR®

### ASSEMBLY INSTRUCTION

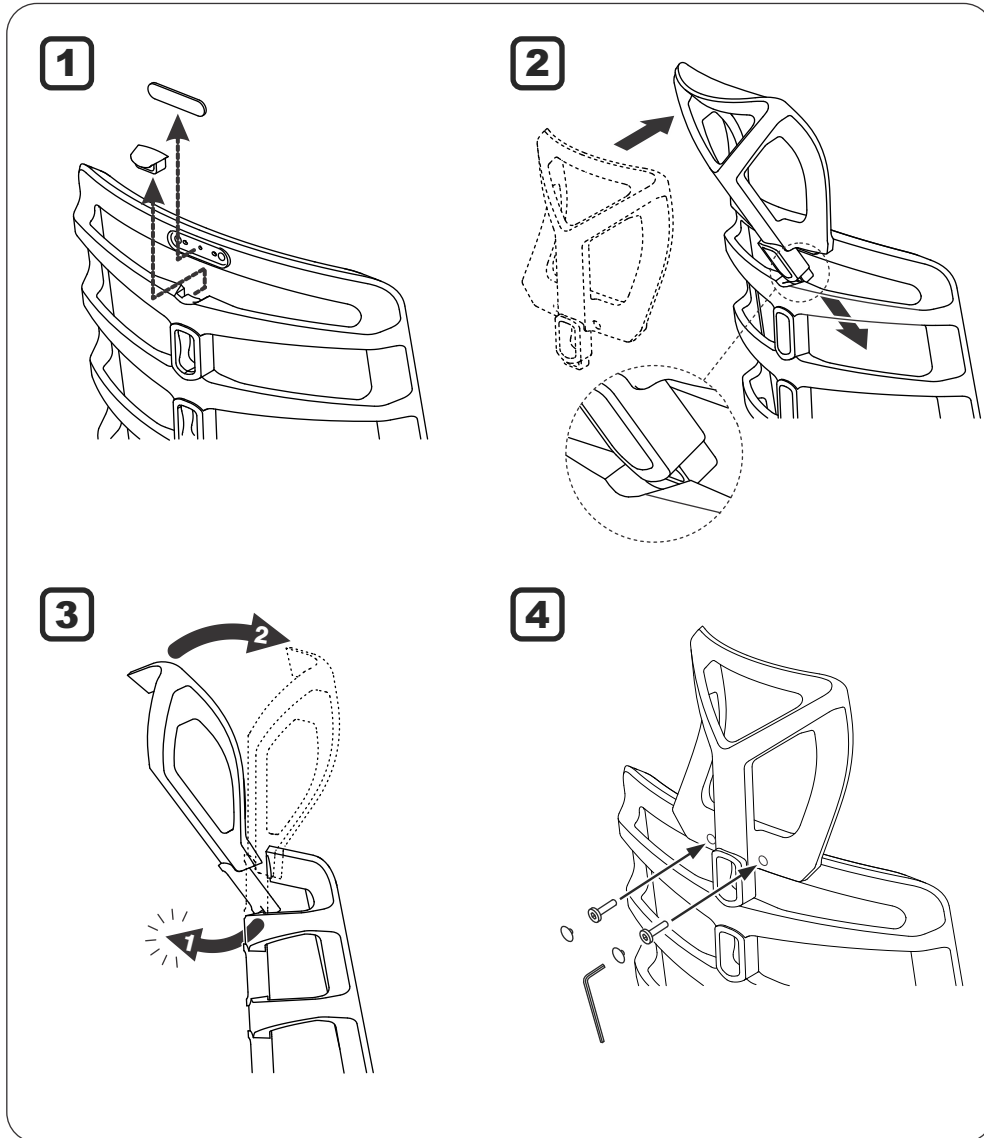

This chair is intended for indoor desk work use.

It is equipped with a swivel base and castors to be highly mobile. As such, NEVER stand on chair to reach for high items or sit on its table or armrests or back since it may move off unexpectedly and result in a falling HAZARD.

#### Care and Maintenance

With regular care and maintenance, your Merryfair SPINELLY seating will provide many years of superior performance and satisfaction. These instructions are provided to you as a service and no warranty is implied since results may vary.

##### Textile Surfaces

###### Normal Cleaning

For normal cleaning, vacuum fabric as needed using an upholstery attachment. Vacuuming picks up dust and reduces the need for professional cleaning. *Do not brush fabric or use a vacuum attachment with a rotary brush. Brushing may permanently damage the nap or change the character of the fabric.*

###### Spot Cleaning

To spot-clean fabric, immediately soak up the stain with a soft absorbent cloth. Do not dry the stain completely or it may set. The longer a stain is allowed to remain on a fabric, the more difficult it is to remove.

For water-based stains such as coffee, soft drinks, fruit juices, or milk use a water-based cleaner (specifically made for cleaning fabric) or a solution of mild (alkaline) warm soapy water (not overly soapy) applied with a damp clean cloth or sponge. Work the cleaner into a lather or foam. *Never use hot water; it will set the stain. Avoid scrubbing.*

For oil-based stains such as lipstick, grease, or salad dressing use a dry cleaning solution applied with a damp clean cloth or sponge. Test the cleaning solution on a small, concealed area first. If there is no spotting, ringing, or damage to the fabric or its dyes, apply the cleaning solution to the soiled area with light, quick strokes. Begin at the outside of the stain and work toward the center, being careful not to over-saturate the fabric.

Do not over apply water or any liquid solution to fabric. Excessive wetting of the fabric with any liquid solution may result in permanent damage to the material.

Do not rub too vigorously or you may damage the nap of the fabric or break fibers. Several light applications are better than one heavy application.

Soak up all remaining solution and then use another clean cloth or sponge dipped in cool water to remove any residue.

Let fabric dry thoroughly and then vacuum well before using. If the stain resists cleaning, call a professional cleaner.

##### Leather Surfaces

For normal cleaning, vacuum or dust frequently with a clean, dry cloth. If leather is soiled, it can be wiped with a soft cloth using specialized leather cleaner.

Do not spot clean leather; clean the entire surface. Wipe clean with a damp cloth and dry with a clean, soft cloth.

For spots and spills, wipe excess liquid immediately with a clean cloth or sponge; let the leather air dry. If further cleaning is necessary, sponge the entire surface with lukewarm water.

Let the leather air dry; never use a hair dryer or other heat source to dry leather. For stubborn spots and stains, apply a mild, nonabrasive soap solution with a clean, wet sponge. Rinse well and let air dry.

For butter, oil, or grease, wipe the leather with a clean, dry cloth and let the remainder of the oil dissipate into the leather. Do not apply water or try to wash a grease spot.

Do not use saddle soap, cleaning solvents, oils, furniture polishes, varnishes, abrasive cleaners, detergents, or ammonia on leather; they will ruin the finish, causing it to become sticky and cracked.

##### Plastic Surfaces – Seat, Back Shell, Base, Table

For normal cleaning, wash surface with a soft cloth soaked in mild detergent and warm water. Rinse thoroughly and dry with a soft cloth. Do not use solvents or abrasive kitchen cleaners.

##### Epoxy powder-coated Metal – Table Support Arm

For normal cleaning, wash coated metal surfaces with a soft cloth soaked in detergent and warm water; rinse thoroughly and dry.

Remove scuff marks from low-gloss coatings with pre-softened paste wax, following the manufacturer's instructions. Remove scuff marks and scratches from high-gloss coatings using automotive polishing compounds, either liquid or paste. After polishing, apply a pre-softened automotive paste wax to restore original sheen.

##### Moving Parts

The moving parts of the chair do not require servicing or lubrication by the user. The adjustment and tilt mechanisms and swivel column are NOT user serviceable components.

**IMPORTANT NOTE:** The swivel column contains a high-pressure gas spring which can cause harm if mishandled by untrained personnel. Please call for authorised service personnel if any of these components malfunction.





# SPINELLY

models: 998P YK A77 NG  
998B YK A77 NP

## ASSEMBLY INSTRUCTION

# MERRYFAIR®

This chair is intended for indoor desk work use. It is equipped with a swivel base and castors to be highly mobile. As such, NEVER stand on chair to reach for high items or sit on its table or armrests or back since it may move off unexpectedly and result in a falling HAZARD.

## USER INSTRUCTIONS

- A Seat Height Adjustment**  
Flip up lever on right-side to raise or lower seat. Adjust such that your feet are adequately supported on floor.
- B Multi-Position Tilt Lock**  
Recline to desired position, and flip down lever on left-side to lock. Flip up lever and recline to release tilt-lock.
- C Tilt Tension fine adjust**  
This chair is equipped with an auto-weight sensing Tilt Tension mechanism. Recline force is automatically adjusted between different users. However, this can be further fine-tuned to suit individual preference by a bottom knob. Turn clockwise to slightly increase tilt tension, and vice-versa.
- D Armrest Height**  
Pull button to unlock armrest and raise or lower it to desired height, and release button to lock. Adjust such that elbows are resting on armpads without straining the shoulders.
- E Lumbar Pad Height**  
Pinch both levers and slide lumbar pad up or down to preferred position.

