

MERRYFAIR®



**FORTE**

Seating Products

**Seating Excellence at Work**

FORTE, is the latest ergonomic seating model by Merryfair to provide a proper support during office routine.



**Comfort**

Forte complies to EN-1335 standard ensuring a comfortable fit to all sizes of user.

**Flexibility**

Use of optimum material and a streamlined back frame design allows your upper back to move freely during tasking.

**Sustainability**

All the parts except the upholstery and foam padding are recyclable at the end of product life cycle.



Forte is made and designed to conform to relevant international standards.

### Headrest

A step-less height adjustable (75mm range) sleek headrest gives optimal support to the user.

### Polyester Mesh

Provides elastic support, yet allowing ventilation for airy comfort.

### Armrest

3-way adjustable A78 armrest can adjust for 100mm height range. Fiber-reinforced polyamide material (100% recyclable) in black colour.

Armpads can move forward or back and swivels into 3 angular positions to allow the user to rest their arms easily. Polypropylene material (100% recyclable) in black colour.

### Base

Standard base is moulded of polypropylene in black colour. 50mm dual-wheels castor of moulded polyamide (Nylon).



### Backrest

Slim back frame design is made of black polyamide plastic.

### Lumbar Pad

Height-adjustable (65mm range) lumbar support range fits comfortably to the curve of your back to provide additional support for you lower back.

### Seat

Seat consist of moulded polyurethane foam on a 2-piece shell structure, injection-moulded in back polypropylene. Seat depth is adjustable for 60mm by sliding seat and controlled by lever. Seat height is adjustable for 100mm by means of a pneumatic gas spring.

### Mechanism

A weight-sensing mechanism auto-adjusts recline resistance according to user weight. Provides 3-position Tilt-Lock, Seat Height and Seat Depth Adjustment.

**Swivel-Tilt Chair  
High Back with Headrest**  
969 YM A78 N2

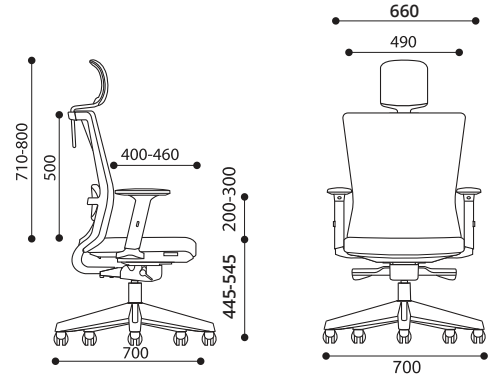
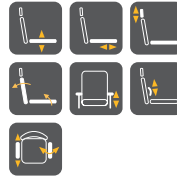

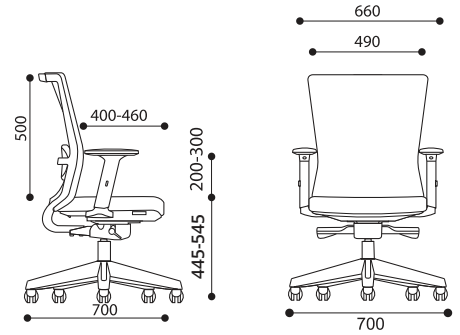

**Swivel-Tilt Chair  
Mid Back**  
968 YM A78 N2

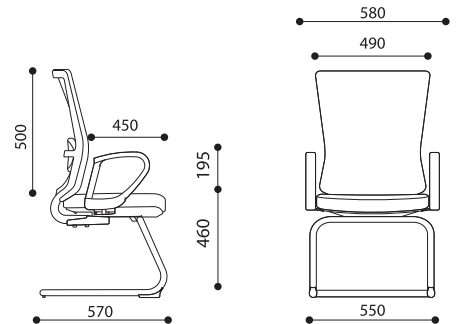

**Visitor Chair  
with Cantilever Base**  
961 NA A15 B





 Pneumatic Seat Height Adjustment

 Adjustable Seat Depth

 Height Adjustable Headrest

 Synchro Mechanism

 Height Adjustable Lumbar Support

 Depth - Angle Adjustable Armpad  
2-way adjustable armpad

 Height Adjustable Armrest

## Forte: Options

### Armrest



3-Way Armrest with PP  
Armpad  
(A78)



3-Way Adjustable Armrest  
with PU Armpad  
(A69)



Fixed Armrest  
(A15)

---

## Base



350 Polished  
Aluminium Base  
(NP)



350 Studio Base  
(N2)



Cantilever Base  
(B)

## HEAD OFFICE & FACTORY

[www.merryfair.com](http://www.merryfair.com)

### Merryfair Chair System Sdn Bhd

(Co. No. 86276-A)  
No.2, Jalan Koporat 1/KU9,  
Taman Perindustrian Meru,  
42200 Klang, Selangor D.E., Malaysia.

### International Sales & Marketing

Tel. +603 3393 2888  
Fax. +603 3393 2000  
[enquiry@merryfair.com](mailto:enquiry@merryfair.com)

### Domestic Sales & Marketing

Tel. +603 3393 6868  
Fax. +603 3393 6888  
[domestic@merryfair.com](mailto:domestic@merryfair.com)

## SHOWROOM OFFICE

### Merryfair Marketing Sdn Bhd

(Co. No. 665054-V)  
No. 82-84, Jalan 2/23A,  
Jalan Genting Kelang,  
53300 Kuala Lumpur, Malaysia.  
Tel. +603 4149 8899  
Fax. +603 4143 0113

## REGIONAL OFFICE & SHOWROOM

### 美力菲 (中国) 家具有限公司

广东省佛山市顺德区容桂华口顺德高新区(容桂)华天路21号  
邮编: 528306  
Merryfair (China) Co.,Ltd  
No. 21, Huatian Road, Shunde High Tech Industrial Zone  
(Ronggui), Huakou Community, Ronggui Subdistrict,  
Shunde District, Foshan City, Guangdong, China 528306.  
Tel. +86 757 2636 9861  
Fax. +86 757 2881 9700  
[domestic@merryfair.com.cn](mailto:domestic@merryfair.com.cn)

### Merryfair (Singapore) Pte Ltd

33 Ubi Avenue 3, #01-52/53 Vertex,  
Singapore 408868.  
Tel. +65 6284 9098  
Fax. +65 6284 9028  
[enquiry@merryfair.com.sg](mailto:enquiry@merryfair.com.sg)

### Merryfair (Thailand) Co.,Ltd.

19/1-2 Sithakarn, Soi Chidlom  
Lumpini, Pathumwan  
Bangkok 10330 Thailand  
Tel : +66 2254 1588  
Fax : +66 2254 1585  
[sales@merryfair.co.th](mailto:sales@merryfair.co.th)

